

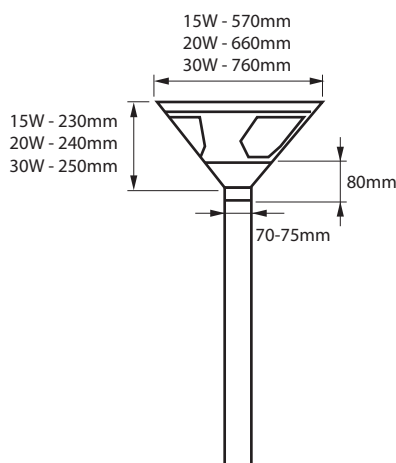

Solar Streetlight RK Series



DIMENSIONS



INTENDED USE

Elegant integrated design easy to transport, install and maintenance. Constant current discharge stable lighting, remote control, night sensor and time controller. Support 3 nights after full charging. Easy to install and auto on/off. High efficiency monocrystalline silicon solar panel to generate electricity. Application for courtyard, garden, park, street, roadway, pathway, parking lot, private road, side walk, public square, plaza, campus, airfield, farm and ranch, perimeter security, wildlife area, remote area, military base.

CONSTRUCTION AND OPTICS

Lithium battery with better weather ability than other battery. Aluminium alloy case, anodic oxidation process bring high corrosion resistance. Thick installation base and brackets bring better wind resistance. 15W, 20W and 30W is available. Colour temperature 6000K to 6500K.

LINE DRAWING

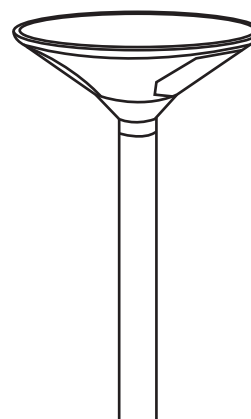

PRODUCT SPECIFICATION

Product Code	Model Code	Lamp Power	LED qty.	Solar Panel	Li-ion Battery	Mounting Height (m)	Installation distance	Packaging Details
STLSRK-15	STLSRK-15	15W 1500lm	72pcs	30W/18V	144WH/12V	3-4m	10-15m	Qty: 1pcs/ctn G.W:7.6kg/ctn Ctn size:660x660x300mm
STLSRK-20	STLSRK-20	20W 2000lm	72pcs	40W/18V	320WH/12V	3-5m	10-20m	Qty: 1pcs/ctn G.W:10kg/ctn Ctn size:740x740x330mm
STLSRK-30	STLSRK-30	30W 3000lm	120pcs	50W/18V	420WH/12V	4-6m	15-20m	Qty: 1pcs/ctn G.W:12.8kg/ctn Ctn size:840x840x330mm